

\* Dimension to suit final post dimensions

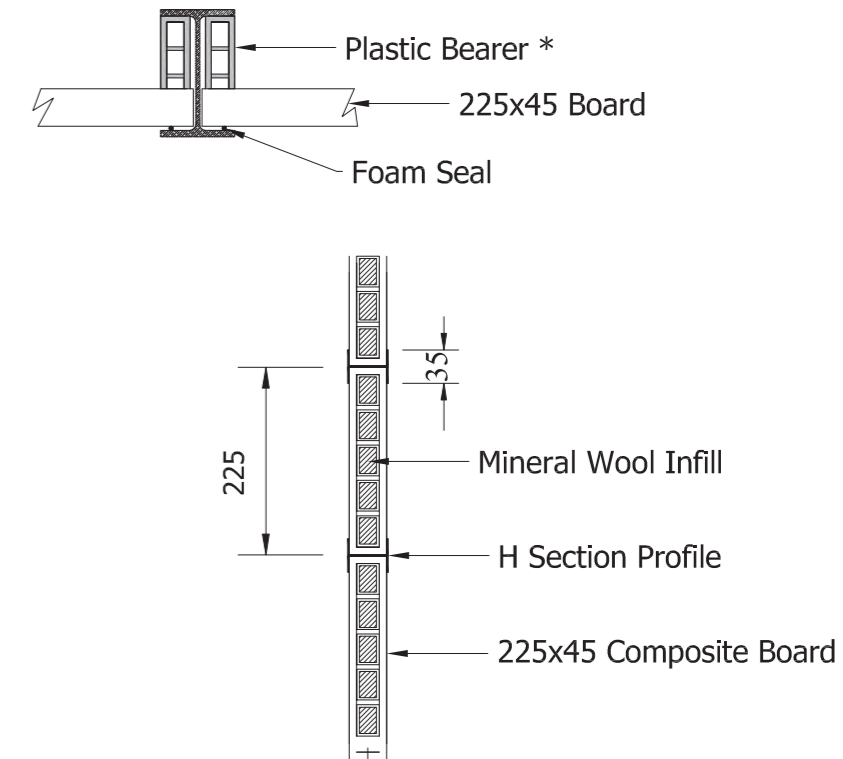

Revision	Description	By	Date
-	-	-	-

STATUS:

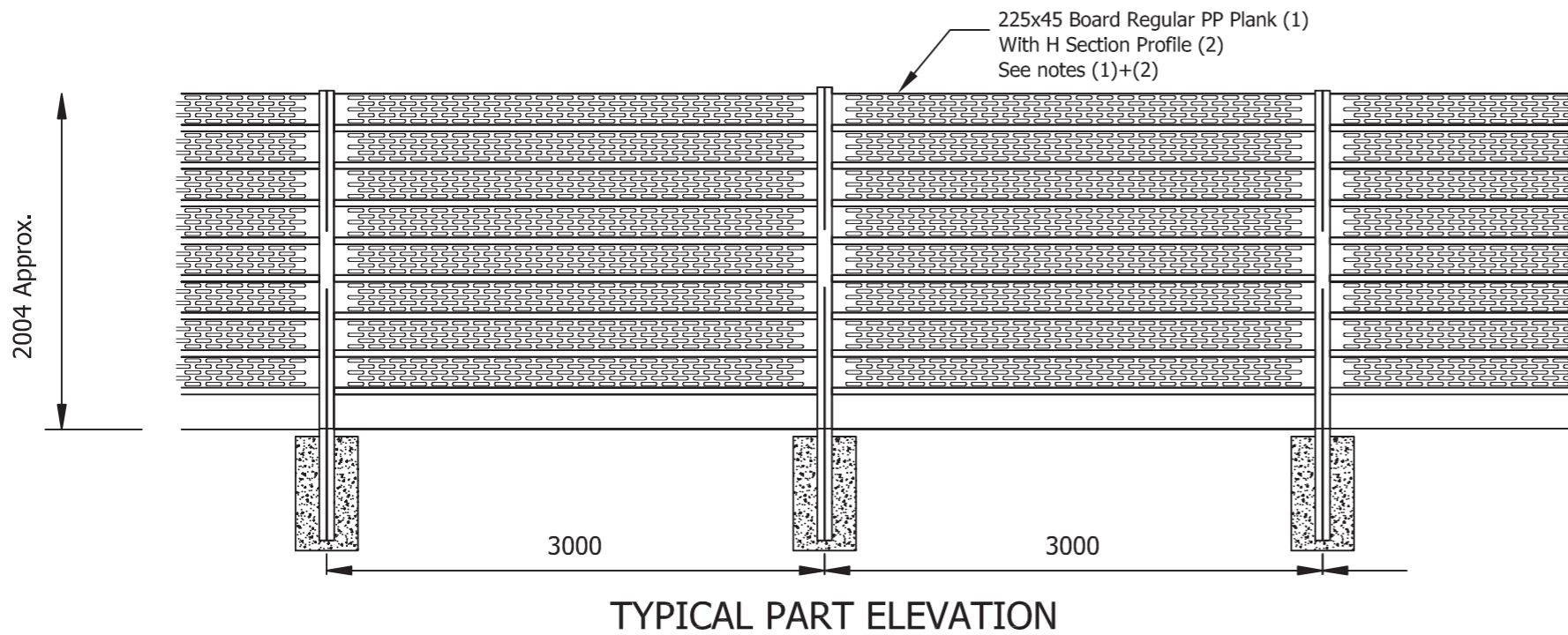
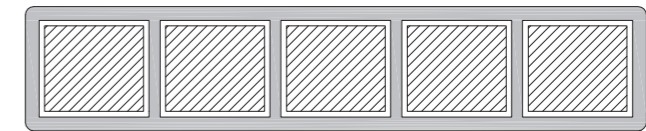
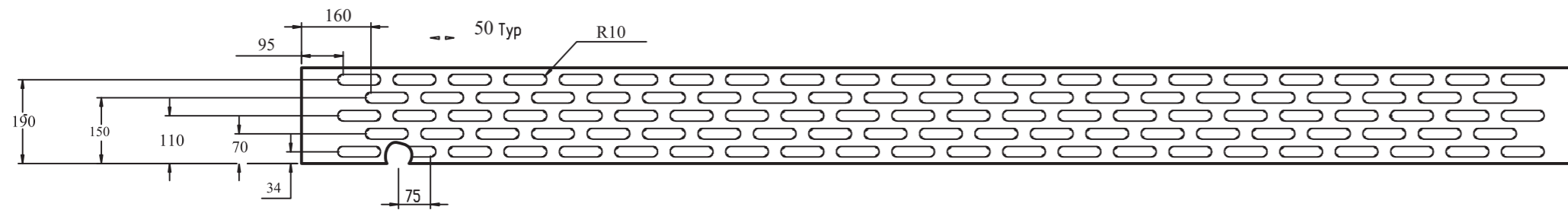

Tilon Ltd.  
Unit 23, Rassau Industrial Estate  
Ebbw Vale, Blaenau  
Gwent, NP23 5SD

Tel: +44 (0) 1495 300 030

Design	RF	25/02/19
Checked	MI	25/02/19
Scale	NTS	

DRAWING TITLE:

Tilon Absorbptive Noise Barrier - TENB45A

PROJECT:

Project No.	Drawing No.	Rev.
		-

